

© COPYRIGHT 19 BY AMP INCORPORATED, HARRISBURG, PA.  
ALL INTERNATIONAL RIGHTS RESERVED. AMP INCORPORATED PRODUCTS  
COVERED BY U. S. AND FOREIGN PATENTS AND/OR PATENTS PENDING.

THIS DRAWING IS UNPUBLISHED.

RELEASED FOR PUBLICATION \_\_\_\_\_, 19\_\_.

		REVISIONS			
P	F	ZONE/LTR	DESCRIPTION	DATE	APPROVED
✓	✓	O	RELEASED	m.s.	6-84
✓	✓	A	REV PER DF-2126	T.W.	8-89
✓	✓	B	REV PER DF-4316	AJC	8-91
✓	✓	C	REV 0600-5641-96	TT	9-97
		D	REV 0600-6467-97	TT	10-97
		E	REV PER OH14-0202-03	CT	1-04
		F	REV PER OH14-0208-05		1-06
		G	ECO-10-002916	PY	2-10
		H	ECO-10-002921	PY	3-10

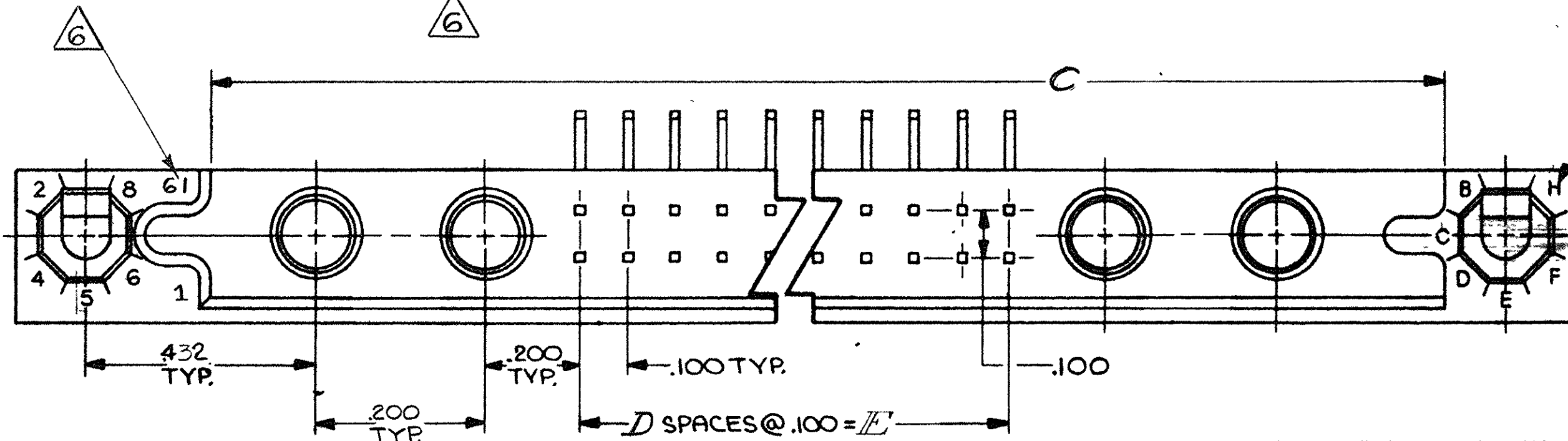
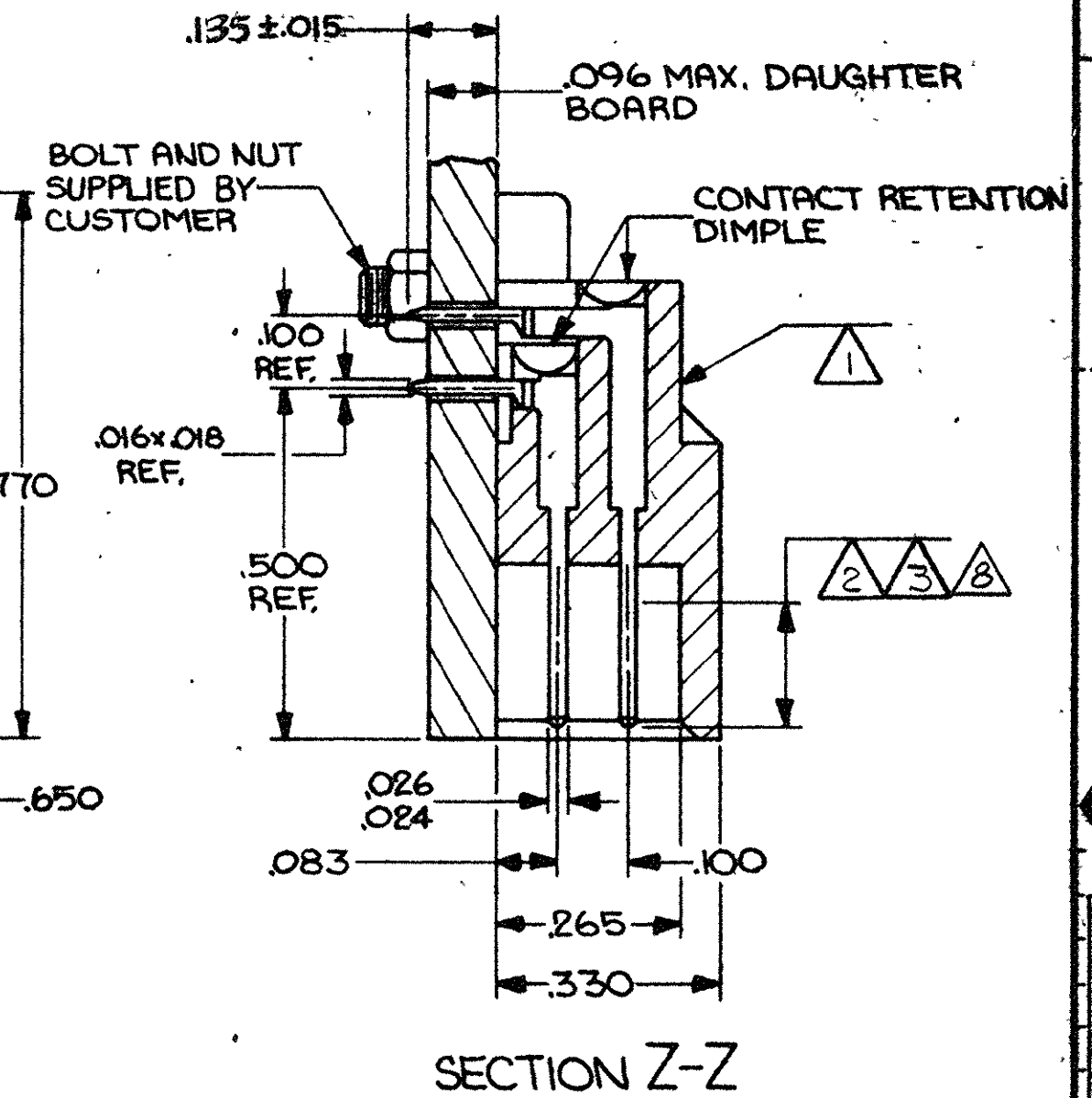
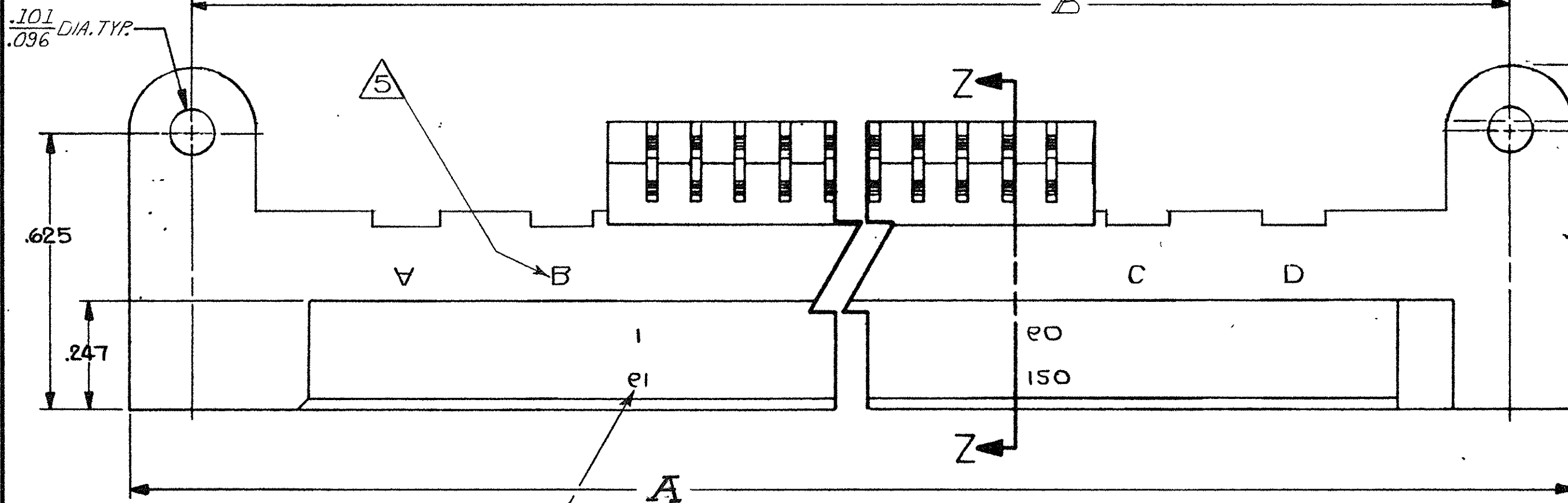
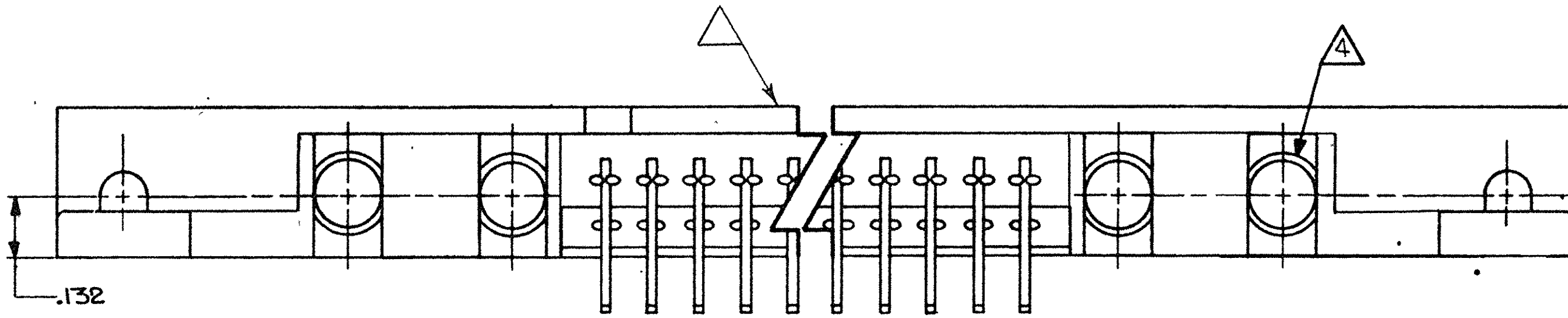

- 1 HOUSING MAT'L.: GLASS-FILLED POLYESTER, COLOR-BLUE.
- 2 CONTACT FINISH: .000050 NICKEL UNDERPLATE ALL OVER, .000050 GOLD IN THIS AREA, .000100 TIN-LEAD ON TAIL.
- 3 CONTACT MAT'L.: BRASS.
- 4 WILL ACCEPT MICROMINATURE COAX CONTACT AMP P/N 227602-1 & 227604-1 INSERT COAX CONTACT P/N 227602-1 FROM THIS SIDE BEFORE MOUNTING TO P.C. BOARD

- CONT. PG. 2 -

UNLESS OTHERWISE SPECIFIED DIMENSIONS ARE IN INCHES. TOLERANCES ON: DECIMALS ±.010 ANGLES ±		CONTRACT NO DR. <i>M. Smith</i> 6-4-84 CHK. <i>P.M. Reagan</i> 6/4/84 APPD. <i>P.M. Reagan</i> 6/4/84 APPD. <i>[Signature]</i> 6/18/84		PART NO	
MATERIAL 1 3	FINISH 2 8	AMP INCORPORATED Harrisburg, Pa.		NAME BOX 1001 SERIES, PIN HEADER ASSEMBLY, WITH COAX	
OTHER APPD.		SIZE C	CODE 00779	IDENT NO 533182	DRAWING NO 533182
		SCALE 4:1	SHEET 1 OF 2		REV H

CUSTOMER DRAWING

533182

THIS DRAWING IS UNPUBLISHED. RELEASED FOR PUBLICATION 19  
 © COPYRIGHT 19 BY AMP INCORPORATED, HARRISBURG, PA. ALL INTERNATIONAL RIGHTS RESERVED. AMP PRODUCTS MAY BE COVERED BY U.S. AND FOREIGN PATENTS AND/OR PATENTS PENDING.

P		F		Z		L		T		R		REVISIONS		
												DESCRIPTION	DATE	APPROVED
												(SEE SHEET 1 OF 2)		

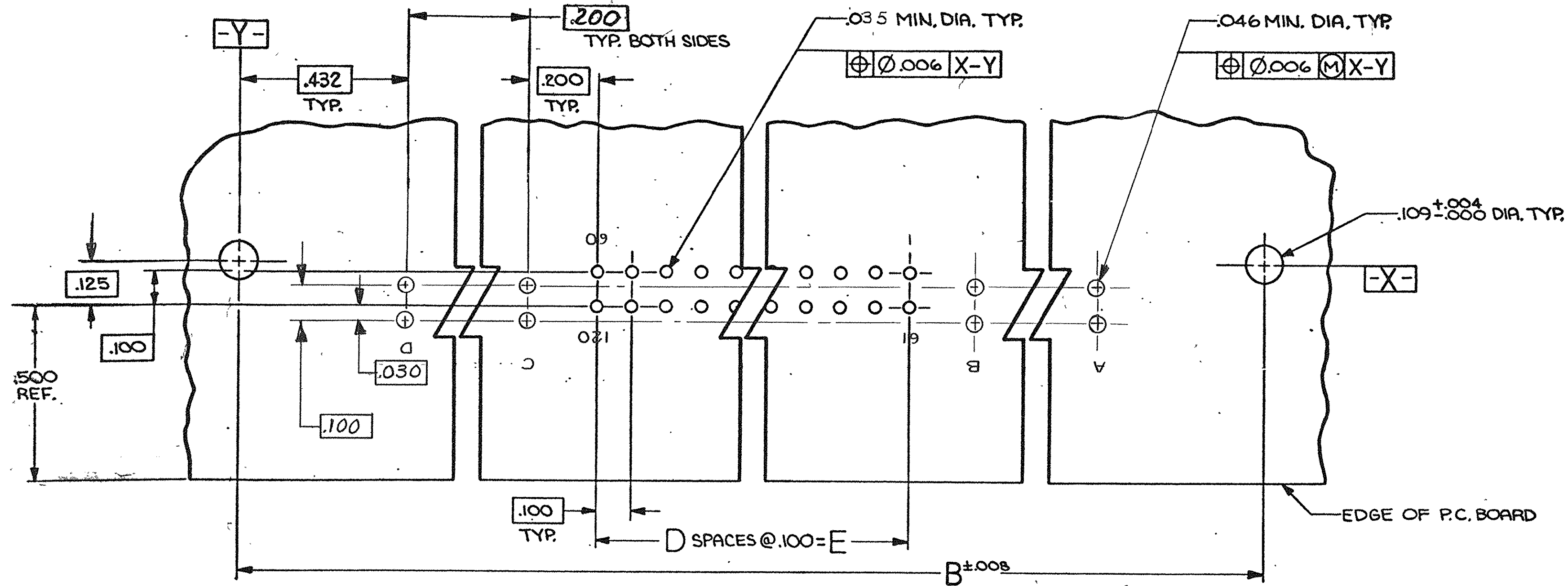

RECOMMENDED P.C. BOARD LAYOUT

- 5 COAX POS. (A, B, C & D) MARKED ON OPPOSITE SIDE ONLY
- 6 CONT. POS. MARKED ON OPPOSITE SIDE ONLY. NUMBERS INDICATING EVERY FIFTH CAVITY MARKED ON SIDE. NUMBERS INDICATING END CAVITIES MARKED ON MATING FACE.
- 7 AMP, P/N & DATE CODE MARKED THIS AREA
- 8 CONTACT FINISH: .000050 NICKEL UNDERPLATE ALL OVER, .000050 GOLD IN THIS AREA, .000100 TIN ON TAIL

8	1.900	19	3.175	3.565	3.855	4	40	5-533182-3
2	5.900	59	7.175	7.565	7.855	4	120	1-533182-0
2	OBS	54	6.675	7.065	7.355	4	110	7-9
	OBS	49	6.175	6.565	6.855	4	100	4-8
	OBS	44	5.675	6.065	6.355	4	90	7-7
	OBS	39	5.175	5.565	5.855	4	80	7-6
	OBS	34	4.675	5.065	5.355	4	70	7-5
2	OBS	24	3.675	4.065	4.355	4	50	7-4
2	1.900	19	3.175	3.565	3.855	4	40	3
2	1.400	14	2.675	3.065	3.355	4	30	2
2	OBS	29	4.175	4.565	4.855	4	60	533182-1
			E	D	C	B	A	

UNLESS OTHERWISE SPECIFIED DIMENSIONS ARE IN INCHES. TOLERANCES ON: DECIMALS ±.010 ANGLES ±	CONTRACT NO		<b>AMP</b>   AMP INCORPORATED Harrisburg, Pa. 17105			
	DR <i>M. Smith</i> 6-4-84	CHK <i>P.M. Reagan</i> 6/4/84				
MATERIAL	ASPD <i>P.M. Reagan</i> 6/4/84	ABPD <i>P.M. Reagan</i> 6/4/84	SIZE C	FSCM NO 00779	DRAWING NO 533182	REV H
FINISH	DSGN/APPD	OTHER APPD	SCALE	SHEET 2 OF 2		

533182